

## LOADSET GIRDER CLAMP

### Capacities: 1 tonne to 10 tonnes

Loadset Girder Clamps are a versatile lifting tool designed for heavy-duty applications, providing an easy to operate and secure means of attaching a lift point to an overhead beam.

- Available in 1t, 2t, 3t, 5t and 10t capacities
- Easily adjusts to suit any girder width in range
- Bottom eye allows simple attachment of a chain block or lever hoist
- Bottom eye swivels for sideways lifting (50% of WLL at 45°)
- Robust all-steel construction
- Stainless steel ID plates
- Proof Load Tested at manufacture (2 x WLL)

CONFORMS TO AS4991

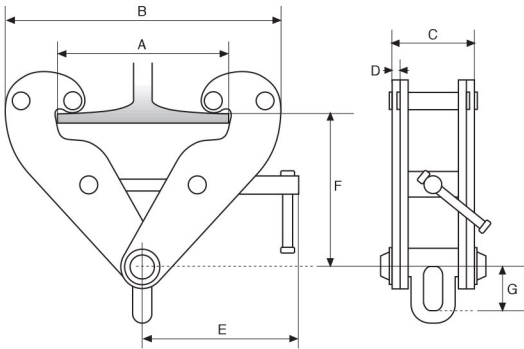

PRODUCT CODE	WLL tonnes	BEAM FLANGE RANGE mm	WEIGHT/unit KG	DIMENSIONS mm								
				Max. A	Max. B	Min. B	C	D	E	Max. F	Min. F	G
GCL01LS	1	75-230	4.5	284	375	180	64	4	218	160	102	45
GCL02LS	2	75-230	5.0	1284	375	180	74	6	218	160	102	45
GCL03LS	3	80-320	10.5	365	498	220	103	8	271	240	168	58
GCL05LS	5	90-320	11.0	365	498	220	110	10	271	240	168	58
GCL10LS	10	90-320	16.0	356	514	250	120	12	280	242	172	90
GCL20LS	20	250-450	42	450	690	500	240	16	410	396	350	90
GCL30LS	30	250-450	45	450	738	528	268	10	432	408	366	90

## LOADSET GIRDER TROLLEYS

### Push Type

### Capacities: 1 tonne to 20 tonnes



- Lightweight robust construction
- Super-quick adjustment to any monorail
- Durable baked enamel paint protection
- Precision ball bearing trolley wheels

CONFORMS TO AS/NZ1418.2

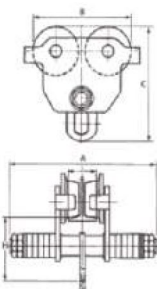

Product Code	GTP1000LS	GTP2000LS	GTP3000LS	GTP5000LS	GTP10000LS	GTP20000LS
Rated Capacity	1.0T	2.0T	3.0T	5.0T	10.0T	20.0T
Adjustable Beam Width	mm 64-305	88-305	100-305	114-305	124-305	136-305
Clearance Dimensions	mm A	413	429	445	457	475
	B	246	276	332	377	442
	C	222	263	309	353	396
	H	125	150	171	196	190
Min. Radius Curve	m 1.0	1.1	1.3	1.4	2.0	3.5
Net Weight	kg 11.5	19	29	43	85	165